



## Hour Meter SM 1112

### Order information

<b>SUPPLY VOLTAGE</b>	220Vac +/-15% 50/60 Hz, 9Vac
-----------------------	------------------------------

<b>DISPLAY</b>	0,36" 5-Digit Display (red or green)
----------------	--------------------------------------

<b>ACCURACY</b>	+/- 0,002% of span, +/- 1 least significant digit
-----------------	---

<b>RESET</b>	Internal Button
--------------	-----------------

### ENVIRONMENTAL CONDITIONS

1	Ambient Temperature	0 - +50 °C
2	Storage Temperature	-20 - +85 °C
3	Humidity	0 - 90% non-condensing

<b>PROTECTION</b>	IP60/IP20 front/back panel
-------------------	----------------------------

### MECHANICAL

1	Dimensions, mm	W48xH48xD87 or W48xH48xD100
2	Weight, g	Approx. 200 (after packing)

### Front Panel

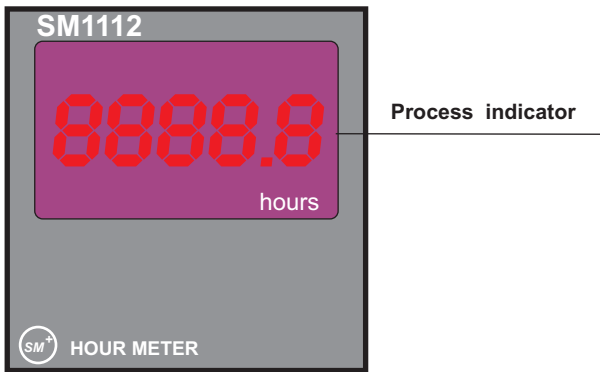

### Display Evidence



Example **1252** = 1252 h

### Dimension, mm

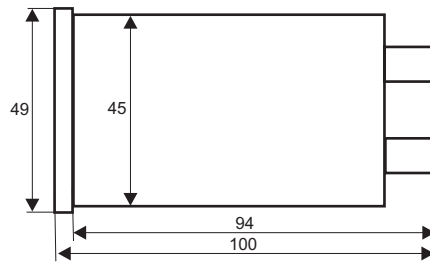

### Electrical Connection

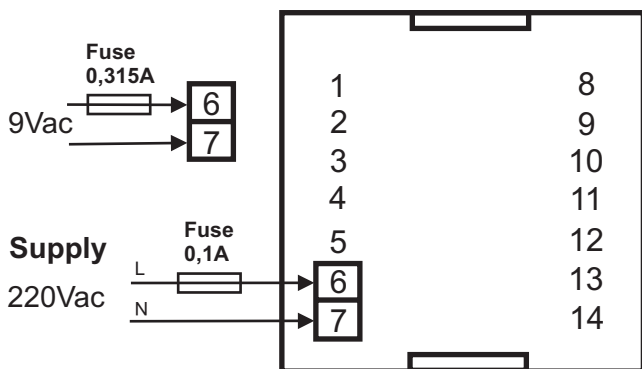

### Panel cut-out, mm

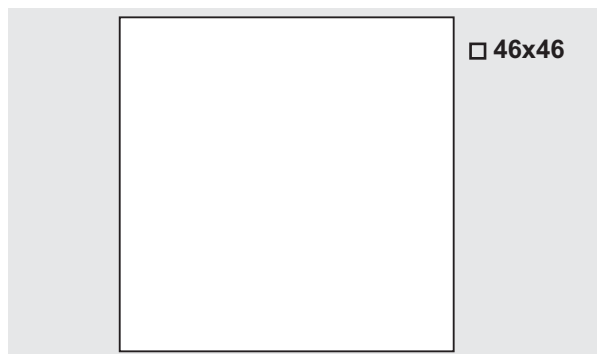

# Hour Meter SM 1112

## Order Code

SM1112-□-□-□-□

**BOX**

1 - Dark grey

**DISPLAY**

R - 0,36' 5-Digit Red Display

G - 0,36' 5-Digit Green Display

**CONNECTORS**

1 - Terminal Blocks

2 - Multi-Connector-Systems

**SUPPLY VOLTAGE**

A - 220Vac +/-15% 50-60Hz

B - 9Vac